

# STC Composite Push-In Fittings

## Y Reducer YR Specifications



### Y Reducer YR Specifications

Specifications	
Operating Pressure Range	0 - 180 PSI (0 - 1200 kpa)
Vacuum	0 - 29.5" Hg (750 mm Hg)
Operating Temperature	32 - 140°F (0 - 60°C)
Recommended Tubing Material	Polyurethane, Nylon, Polyethylene, Polypropylene
Metal Body	Brass, Nickel Plated
Plastic Body	PBT (Polybutylene Terephthalate)
Release Button	POM (Polyoxymethylene copolymer)
Grip Ring or Collet	300 Series Stainless Steel
O-Ring	NBR (Buna-N)
Thread Sealant	Teflon
Service	FOR AIR

# Composite Push-In Fitting Components

## Composite Push-In Fitting Materials of Construction

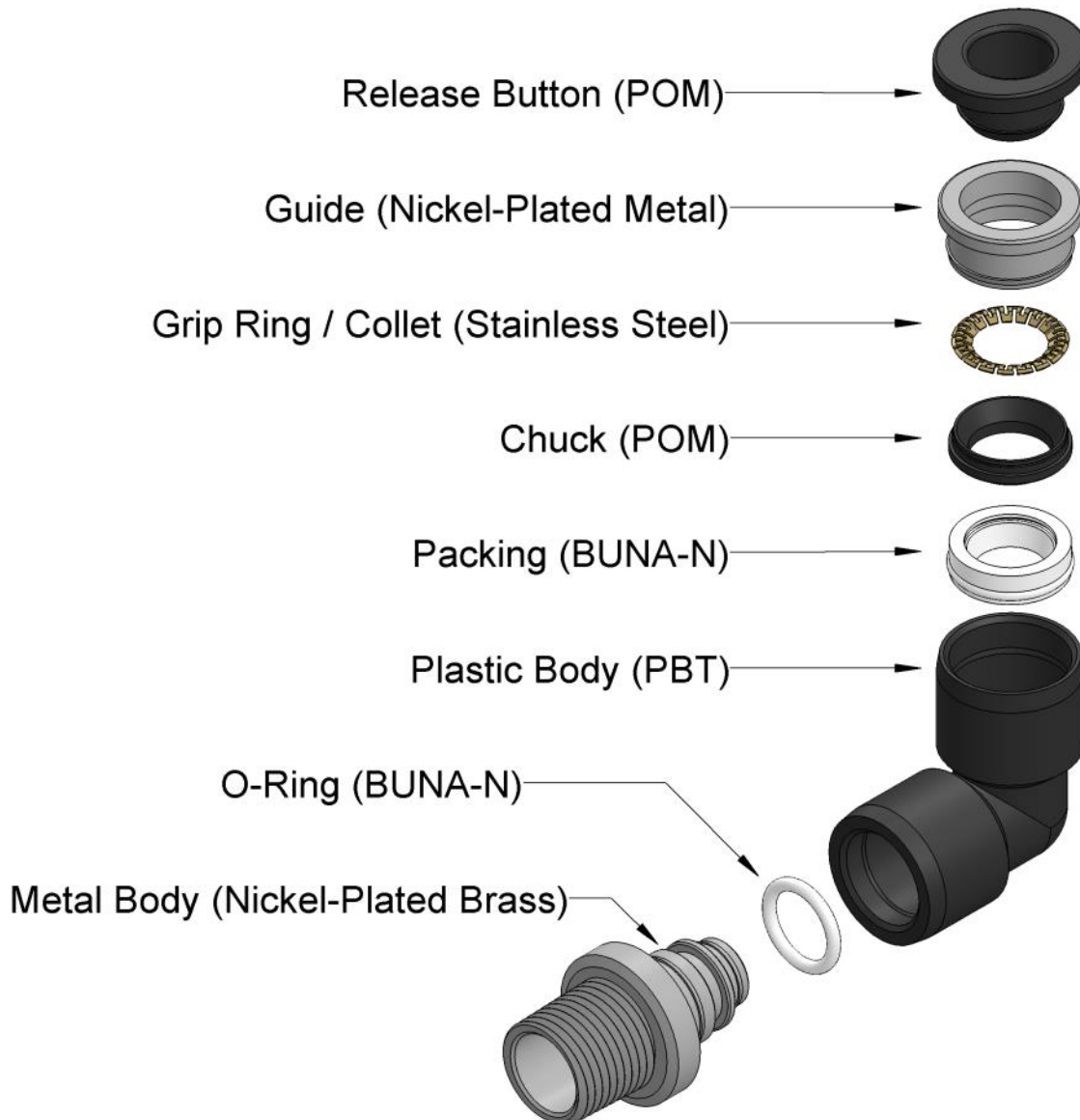

# Material Test Reports

This document certifies that STC products have been subjected to quality assurance procedures and meet the material and performance specifications published by Sizto Tech Corporation (STC). The products have been manufactured, processed, inspected, and tested according to STC internal requirements and ISO 9001 standards.

ISO 9001:2015 Certificate Number: **Qnb17180318**  
 Date of Issue: **01, March, 2018**  
 Valid Until: **28, February, 2021**

Individual materials and components used in this product have been tested and conform to applicable published standards according to chart below. Please be advised that STC does not conduct its own material analysis of all raw materials, rather, STC relies on the statements of its material suppliers & reserves the rights to independently test raw materials if necessary. Material Test Reports may be available for specific products upon request.

Material	Use Location	Material Standard
316 Stainless Steel	Metal Fittings, Valves, Air Cylinders	ASTM A240/A2666
304 Stainless Steel	Valves, Air Cylinders	ASTM A240/A666
CF8M Stainless Steel	Valves	ASTM A351/A743
Brass	Valves	ASTM B36/B62
Nickel-Plated Brass	Composite Fittings	ASTM B456/B927
Acetal Homopolymer (Delrin)	Valves	ASTM D4181/D6778—14
Acetal Copolymer (POM)	Composite Fittings	ASTM D4181/D6778—14
FKM (Viton)	Seals	ASTM D1418
PTFE (Teflon)	Valves, Seals	ASTM D3294—15
NBR (Buna N)	Seals	ASTM D1387—06
EPDM	Seals	ASTM D3568—03
Polybutylene Terephthalate (PBT)	Composite Fittings	ASTM D4000



# Composite Push-In Fitting Installation Procedure

## A. Installation of Pipe Fittings

1. Tighten fitting by hand, then turn it 2-3 turns with a wrench until it reaches the desired torque listed. If the fittings are not pre-coated with sealant, or is used and the sealant is not in good condition, apply Teflon sealant tape to the threads.

Recommendation of Torque for Tightening Fittings		
Fitting Thread Size	Torque, lb-ft	Torque, kgf/cm
10-32, M5 - M6	1.0 - 1.5	14 - 21
NPT 1/8, R1/8	5 - 6.5	70 - 90
NPT 1/4, R1/4	8.5 - 10	120 - 140
NPT 3/8, R 3/8	16 - 17.5	220 - 240
NPT 1/2, R 1/2	20 - 21.5	280 - 300

## B. Installation of Tubing into Fitting:

1. Slowly push a clean and perpendicularly cut tube into the fitting until it comes to a dead stop.
2. Gently pull the tubing back until the Grip Ring or Collet of the fitting grips onto the tubing and has a good seal.
3. Use Polyethylene, Polypropylene, Polyurethane, or Nylon tubing designed for instant fittings.

## C. Removal of Tubing from Fitting:

1. Push in evenly on the two long, oval sides of the Release Button.
2. Pull out the tube while depressing the Release Button.
3. To reuse the tubing, cut off the lodged portion of the previously used tubing in an even and perpendicular fashion.

## D. Recommended Tubing Material, Size, and Hardness Requirements:

Tubing Material	Specified Size	Hardness (Durometer)
Polyurethane	+/- 0.006" (+/-0.15 mm)	Shore A 85 or higher
Polyethylene	+/- 0.004" (+/-0.1 mm)	Shore D 44 - D75
Polypropylene	+/- 0.004" (+/-0.1 mm)	Shore D 44 - D75
Nylon	+/- 0.004" (+/-0.1 mm)	Shore D 44 - D75
Pre-grooved Metal Tubing	+/- 0.004" (+/-0.1 mm)	

# Composite Push-In Fitting Dimensions

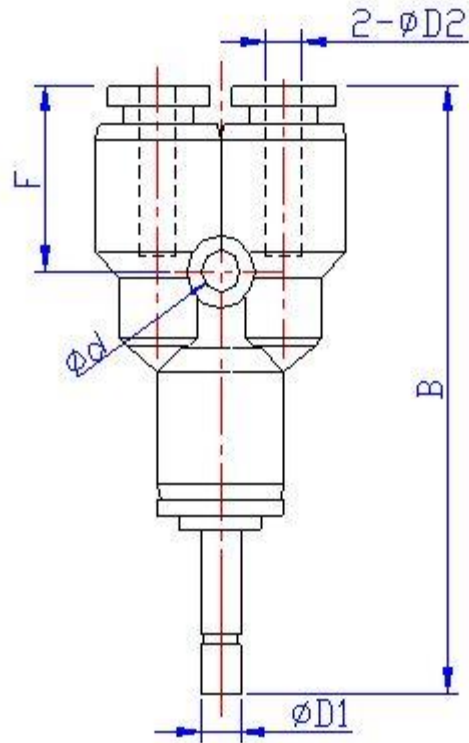

Y Reducer (Tube-Stem) YR Dimensions					
Model	φD1	φD2	φd	B	F
YR 5/32-1/4	1/4	5/32	3.2	53.0	14.0
YR 1/4-5/16	5/16	1/4	3.2	57.3	14.8
YR 5/16-3/8	3/8	5/16	4.2	64.1	18.2

**Note:** Dimensions are for reference only. Field verify dimensions prior to installation for critical dimensions.

# Terms & Conditions

By purchasing from SIZTO TECH CORPORATION (STC), you agree to these TERMS AND CONDITIONS. No other terms shall apply except as agreed in writing & signed by STC. We reserve the right to correct typographic errors and reject orders.

## SHIPMENTS:

All shipments are F.O.B. 892 Commercial Street, Palo Alto, CA 94303, USA. Most orders are shipped via UPS Standard Ground unless instructions accompany order. Outside the UPS zones, shipment will be made Best Way. The responsibility for goods delay, lost or damaged in transit rests with the carrier and purchaser. Purchaser may purchase shipping insurance to cover lost or damaged products caused by shipping.

## RETURN OF MERCHANDISE:

No merchandise is accepted for return 30 days after delivery date. No credit allowed on merchandise shipped as ordered and returned without obtaining an authorization number IN ADVANCE. A 20% restocking charge applies to all returns, and transportation charges must be fully prepaid. We will pay **ground** transportation charges on re-sent or returned merchandise due to STC's error.

**Shortages & Mis-Shipments:** Any shortages or mis-shipments must be reported within 15 days.

## CANCELLATION POLICY:

Blanket orders can be canceled 90 days before scheduled ship date. There will be a 10% charge if a blanket order is canceled within 90 days of scheduled ship date, and a 20% charge if canceled within 60 days. Regular orders for non-custom parts can be canceled any time before the order is shipped. For custom parts, a 30% down payment is required either at the time of order or 90 days prior to scheduled ship date, whichever comes later.

## Remittances should be sent to:

Sizto Tech Corporation, 892 Commercial Street, Palo Alto, CA 94303, USA

Credit Card Payments: Visa, MasterCard, Discover, or American Express accepted

**International Customers:** Advance Payment Required via Bank Wire, Cashier's Check or Approved Credit Card.

**Credit Application:** To establish a net 30 day account, please mail or fax three trade references with complete mailing addresses and account numbers, or request an STC Credit Application.

## LIMITED WARRANTY – IMPORTANT NOTICE TO PURCHASER:

Sizto Tech Corporation (STC) only warrants this product to be free from defects in materials and workmanship at the time of shipment. This limited warranty expires one year after delivery to the end-user. STC's entire obligation to the Purchaser for breach of this limited warranty shall be limited to replacement of the defective product or refund of the original purchase price of this product, at STC's option. Purchaser has thirty (30) days to return the goods after STC has agreed to accept the return. All freight charges on returned material shall be paid by the Purchaser. STC's limited warranty shall not apply, however, to the product that have been subjected to misuse, alteration, accident or negligence during handling or storage.

## DISCLAIMER OF IMPLIED WARRANTIES:

All implied warranties, which may arise by implication of law or application of course of dealing or usage of trade, including, but not limited to, implied warranties of merchantability or fitness for a particular purpose are expressly excluded. There are no warranties, which extend beyond the description of the faced hereof. The end user is solely responsible for the suitability and fitness of this product selected for a particular application.

## OBLIGATIONS

You warrant, represent and agree: (1) to comply with all laws; (2) that our sale and shipment of the product will not, by export thereof, your legal status or otherwise, cause us to violate any law; and (3) to indemnify us against any losses from a failure by you or a third party to comply with law or these terms and conditions, or from use of the product.

## SAFETY

**WARNING:** Improper Selection or Failure to follow Usage Instructions of the products described on the Sizto Tech Corporation (STC) Internet Site and its related publications can cause Death, Personal Injury, and Property Damage. All system set-ups require the supervision of a qualified individual who is familiar with installation, inspection and testing through training or experience.

## IMPORTANT NOTICE:

All prices are subject to change without notice. We continuously improve the products, and we reserve the right to change specifications without incurring any obligation to incorporate new factors in equipment previously sold.

Information contained herein may be changed without prior notification.

Sizto Tech Corporation

892 Commercial Street

Palo Alto, CA 94043 USA

Tel: 650-856-8833 | Fax: 650-856-8811

Email: Sales@StcValve.com | www.StcValve.com



[www.StcValve.com](http://www.StcValve.com)